

Head Office & Factories:
 Unit B Venture Buildings, Pendle Trading Estate,
 Chatburn, Lancs. BB7 4JY UK
 Tel: +44(0)1200 440383 Fax: +44(0)1200 441628
 Email: sales@valleyhydraulics.co.uk
 Web: www.valeyhydraulics.co.uk

DATA SHEET

SX SERIES RAMPUMP

38mm Bore,
 150mm - 1000mm Stroke



Lodematic **SX Series Rampumps** combine a 38mm bore single acting cylinder with the rugged Lodematic HP2 Handpump.

Modular construction eliminates the needs for external pipework, an external 3/8" BSP parallel connection port simplifies tandem cylinder layouts.

Ideally suited to tilt-deck car transporters, plant trailers, conveyors, stacker trucks etc., the **Rampump** provides the all weather, heavy duty solution to your lifting problems.

Specification

MAXIMUM THRUST:
 2000 Kg at 170 bar

STROKES AVAILABLE:
 150 - 1000MM

MAXIMUM ARTICULATION:
 30° from vertical

RESERVOIR VOLUME:
 1.7 litres

APPROXIMATE WEIGHT:
 17 Kg

CONSTRUCTION:
 Aluminium free

FINISH:
 Painted Silver,
 NCB white optional extra

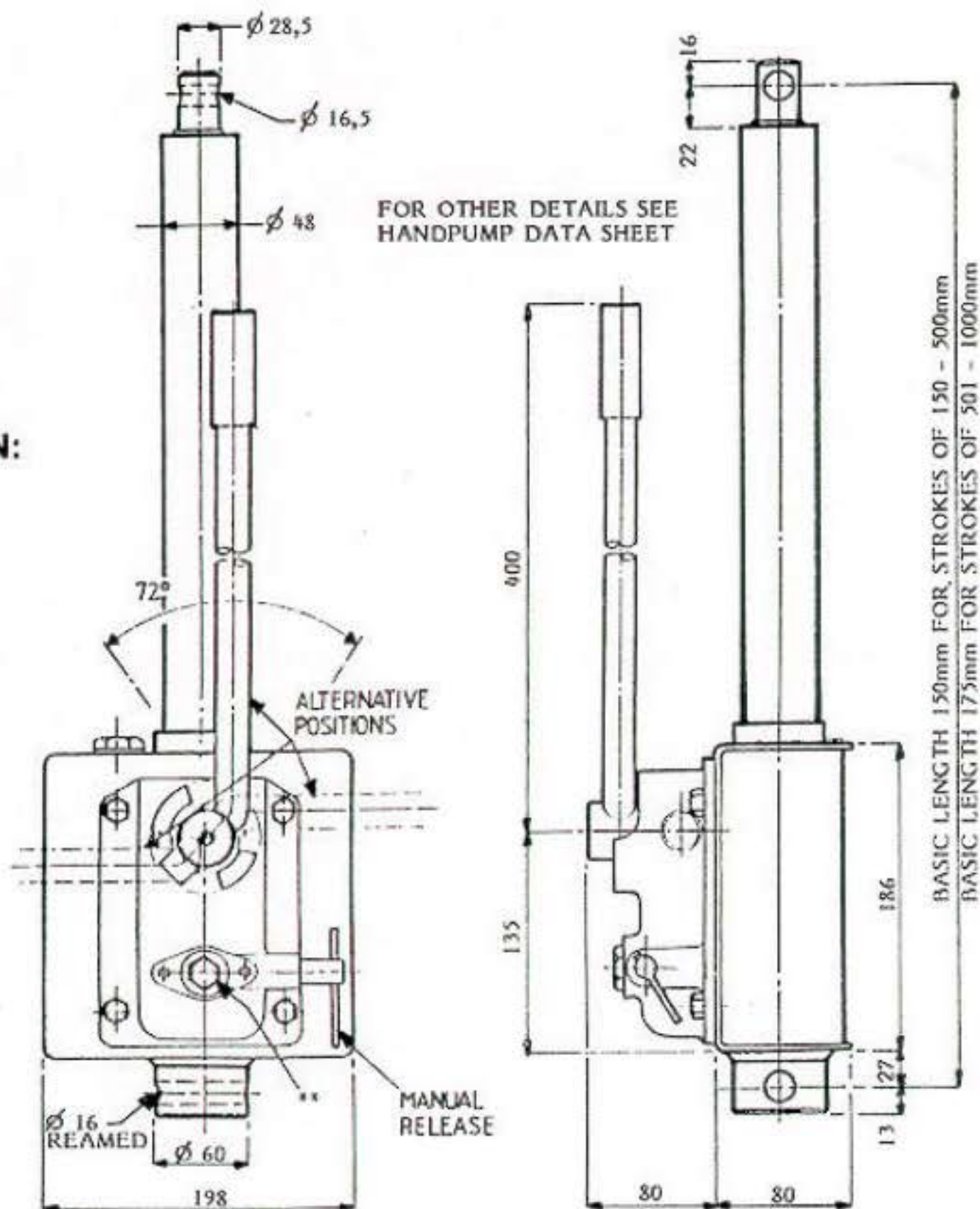

Ordering Data - Specify Rampump model and stroke required e.g. SX 650, Rampump with 650mm stroke, standard finish and painted silver.